

XI'AN IR-PERI



PRELIMINARY

MZC75TS120S

MZK75TS120S

Fast Recovery Epitaxial Diode INT -A -PAK

Soft-Fast™ Speed FRED

Features

- International standard package
With DBC ceramic base plate
- Planar passivated chips
- Short recovery time
- Low switching losses
- Ultra-soft recovery behaviour
- Industry standard package
- UL recognition pending

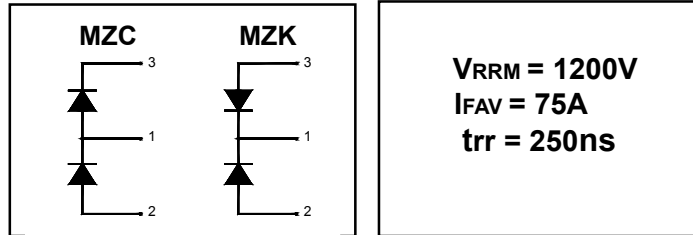

Benefits

- Antiparallel diode for high frequency switching devices
- Increased operating efficiency
- Direct mounting to heatsink
- Uninterruptible power supplies (UPS)
- Ultrasonic cleaners and welders
- Low voltage peaks for reduced protection circuits

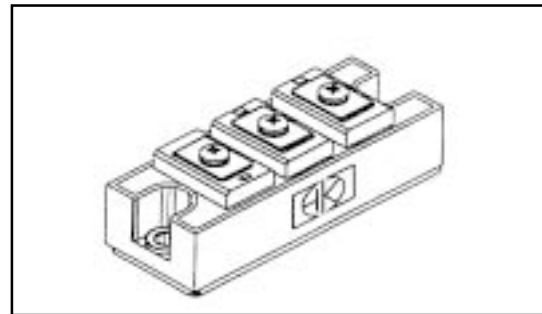

Absolute Maximum Ratings

Symbol	Test Conditions	Max.	Units
V _{RSM} & V _{RRM}		1200	V
I _{FRMS}	T _C =75 °C	107	A
I _{FAV}	T _C =75 °C; rectangular, d=0.5	75	A
I _{FRM}	t _p <10µs; rep. rating, pulse width limited by T _{VJM}	400	A
I _{FSM}	T _{VJ} =45 °C; t=10ms (50 Hz),sine	1200	A
	t=8.3ms (60 Hz),sine	1300	A
	T _{VJ} =150 °C; t=10ms (50 Hz),sine	1080	A
	t=8.3ms (60 Hz),sine	1170	A
I ² t	T _{VJ} =45 °C; t=10ms (50 Hz),sine	7200	A ² s
	t=8.3ms (60 Hz),sine	7100	A ² s
	T _{VJ} =150 °C; t=10ms (50 Hz),sine	5800	A ² s
	t=8.3ms (60 Hz),sine	5700	A ² s
V _{ISOL}	RMS Isolation Voltage, Any Terminal To Case, t=1 min	2500	V
P _D	T _C =25 °C	310	W
T _J	Operating Junction Temperature Range	-40 to +150	°C
T _{STG}	Storage Temperature Range	-40 to +125	

Thermal / Mechanical Characteristics

	Parameter	Typ.	Max.	Units
R _{θJS}	Thermal Resistance, Junction-to- Sink DC	-	0.48	
R _{θJC}	Thermal Resistance, Junction-to- Case DC	-	0.40	°C/W
R _{θCS}	Thermal Resistance, Case-to- Sink- Module	0.08	-	
	Mouting Torque, Case-to-Heatsink	-	4.0	N.m
	Mouting Torque, Case-to-Terminal 1,2 & 3	-	3.0	
	Weight of Module	200	-	g

Electrical Characteristics (unless otherwise specified)

	Parameter	Min.	Typ.	Max.	Units	Conditions
V _{RRM}	Reverse Breakdown Voltage	1200	-	-	V	I _R =2mA
I _R	Diode Leaking Current	-	-	2	mA	T _{VJ} =25°C V _R =V _{RRM}
		-	-	0.5	mA	T _{VJ} =25°C V _R =0.8V _{RRM}
		-	-	20	mA	T _{VJ} =125°C V _R =0.8V _{RRM}
V _F	Diode Forward Voltage	-	-	1.85	V	I _F =100A; T _{VJ} =125°C
		-	-	2.17	V	T _{VJ} = 25°C
		-	-	2.58	V	I _F =300A; T _{VJ} =125°C
		-	-	2.64	V	T _{VJ} = 25°C
V _{TO}	For power-loss calculations only	-	-	1.48	V	
r _T		-	-	3.65	mΩ	
trr@T _{VJ} =100°C	Diode Reverse Recovery Time	-	250	300	ns	I _F =150A
I _{RM} @T _{VJ} = 25°C	Diode Peak Reverse Current	-	-	22	A	V _R =600V
I _{RM} @T _{VJ} =100°C	Diode Peak Reverse Current	-	-	33	A	-di/dt=200A/μs

Case Outline - int-a-pak

